

LANSRCNH74

Installation Instructions

Lankota Stalk Roller Kit for 4WD CIH Wheeled (500,450, 540, 550,580,600,620) & NH T.9 Tractors

without Front Weight

**** Not for tractors with tread wider than 198" ****

LANKOTA®

270 West Park Avenue

Huron, SD 57350

866-526-5682

Numerical Parts List

Part Numbers	Description	Qty
LANSRCNH4T002	Tractor Main Mount	1
LANSRCNH4T002M	Tractor Main Mount	1
LANSRCNH4T003	Mount Cross Brace	1
LANSR035BLK	Stalk Roller Assembly	2
LANSR005BLK	Stalk Roller Mount Frame	1
LANSR038BLK	Stalk Roller Wing Frame	1
LANSR039BLK	Stalk Roller Wing Frame	1
LANSR008	Stalk Roller Wing Pin	2
LANSR009	Stalk Roller Plastic Washer	4
LANW250100-S	Hydraulic Cylinder for Stalk Rollers	2
LANSSQT230L	Mount Spacer Left	1
LANSSQT230R	Mount Spacer Right	1
LANSSQT231	Toolbox Bracket	2
LANSS704	Stalk Stomper Pin Assembly - Bent Pin	2
LANSCA-1	1" Cylinder Stroke Control	4
LANSRCNH52BH	Box of Hardware	1
LAN690830	5/8" Serrated Flange Nut	36
LAN18A00	3/8"-16 x 1" Bolt	2
LAN26B00	5/8"-11 x 2" Bolt	4
LANFC507	1/2"-13 x 1 3/4" Bolt	2
LANFWS53	SAE Flat Washer 3/8"	2
LANFWS57	SAE Flat Washer 5/8"	12
REDODTT	3/8" Top Lock Nut	2
RED1F30	1/2" Top Lock Nut	2
REDB710	5/8"-11 x 2.5" Bolt	8
LAN44302	Zip Tie, 11"	12

Numerical Parts List (Continued)

Part Numbers	Description	Qty
REDWU58	3/4" Flat Washer	24
LANFB810	3/4" x 2 1/2" Hex Bolt, Gr. 5	8
LANFB808	3/4" x 2" Hex Bolt, Gr. 5	4
LANFXFY9	3/4" Center Lock Nut	12
REDB306	3/8" x 1 1/2" Hex Bolt, Gr. 5	6
LAN18000	3/8" Flat Washer	6
LAN3718	3/8" Serrated Flange Nut	6
LAN079UBOLT	U-Bolt, 5/8"-11 x 6.5"	12
LANSRHRTBH	Bag of Hardware Includes:	1
LAN25162	Double 1" Hose Clamp with Cushion	2
REDB204	Hex Head Cap Screw—5/16"-18 x 1.00", gr. 5	2
LANFWS52	5/16" SAE Flat Washer	2
LAN1616	Nyloc Nut - 5/16"-18, gr. 5	2
LAN44302	11" Zip Tie	12

Numerical Parts List (Continued)

Part Numbers	Description	Qty
LANSRJD8RHK	Stalk Roller Hose Kit	1
-----	26' (312") x 3/8" Hydraulic Hose, JIC 6F	2
-----	28" x 3/8" Hydraulic Hose, JIC 6F	2
-----	40" x 3/8" Hydraulic Hose, JIC 6F	2
-----	52" x 3/8" Hydraulic Hose, JIC 6F	2
-----	64" x 3/8" Hydraulic Hose, JIC 6F	2
-----	1/32" Orifice Male to Female Adapter	2
6400-06-06	9/16" Male JIC to 9/16" Male ORB	2
2603-06-06-06	9/16" Male JIC Tee	2
DINB12-F-08N	1/2" Female NPT Quick Coupler	2
5601-08-08-08	1/2" Female NPT to 1/2" Male NPT Tee	2
DINB12-MS-08N	1/2" NPT Male Coupling	2
2404-06-08	9/16" Male JIC to 1/2" Male NPT	2
6801-06-06	9/16" Male JIC to 9/16" Male ORB 90 Deg	4
2403-06-06	9/16" Male JIC to 9/16" Male JIC Coupler	2

Pictorial Parts List

 <p>LANSRCNH4T002 (1)</p>		 <p>LANSRCNH4T002M (1)</p>		 <p>LANSRCNH4T003 (1)</p>	
 <p>LANSR035BLK (2)</p>	 <p>LANSR005BLK (1)</p>	 <p>LANSR038 (1)</p>	 <p>LANSR039 (1)</p>	 <p>LANSR008 (2)</p>	 <p>LANSR009 (4)</p>
 <p>LANW250100-S (2)</p>	 <p>LAN079UBOLT (12)</p>	 <p>LANSSQT230L (1)</p>	 <p>LANSSQT230R (1)</p>	 <p>LANSSQT231 (2)</p>	 <p>LANSS704 (2)</p>
 <p>LANSCA-1 (4)</p>	 <p>LAN690830 (36)</p>	 <p>LAN18A00 (2)</p>	 <p>LAN26B00 (4)</p>	 <p>LANFC507 (2)</p>	 <p>LANFWS53 (2)</p>

Pictorial Parts List (Continued)

					
LANFWS57 (2)	RED0DTT (2)	RED1F30 (2)	REDB710 (8)	LAN44302 (24)	REDWU58 (24)
					
LANFB810 (8)	LANFB808 (4)	LANFXFY9 (12)	REDB306 (6)	LAN18000 (6)	LAN3718 (6)
					
LAN25162 (2)	REDB204 (2)	LANFWS52 (2)	LAN1616 (2)		

Disclaimer

This kit from LANKOTA adds 1300 lbs. to the front of a tractor. Never exceed manufacturer's specified load limit on the front of a tractor!

WARNING: After completing installation, be careful around the wings the first dozen or so times they are folded/unfolded. The process of purging the air from the hoses can cause the wings to jerk up and down dangerously and unexpectedly.

Kit Installation

Refer to Figures 1,2 & 3

1. Remove the toolboxes and brackets on each side of the tractor.
2. Starting on one side, bolt the mount spacer (LANSSQT230L) to the bottom of the front of the tractor through the three available holes with 3/4" x 2 1/2" bolts (LANFB810), 3/4" washers (REDWU58) and 3/4" lock nuts (LANFXFY9).
3. Attach the mount (LANSRCNH4T002) to the spacer using a 3/4" x 2 1/2" bolt in the front hole (shown with a red arrow), two 3/4" x 2" bolts (LANB808), 3/4" washers, and 3/4" lock nuts. Snug the nuts but do not tighten them at this time.
4. Attach the toolbox bracket (LANSSQT231) to the spacer (LANSSQT230L) with three 3/8" x 1 1/2" bolts (REDB306), 3/8" washers (LAN18000) and 3/8" serrated nut (LAN3718) inside.
5. Repeat Step 2 – 4 for the opposite side.

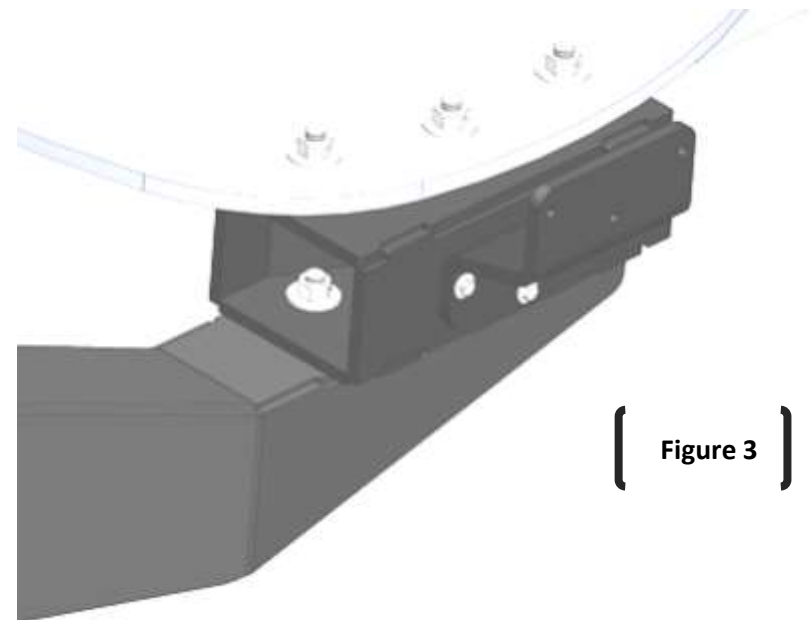
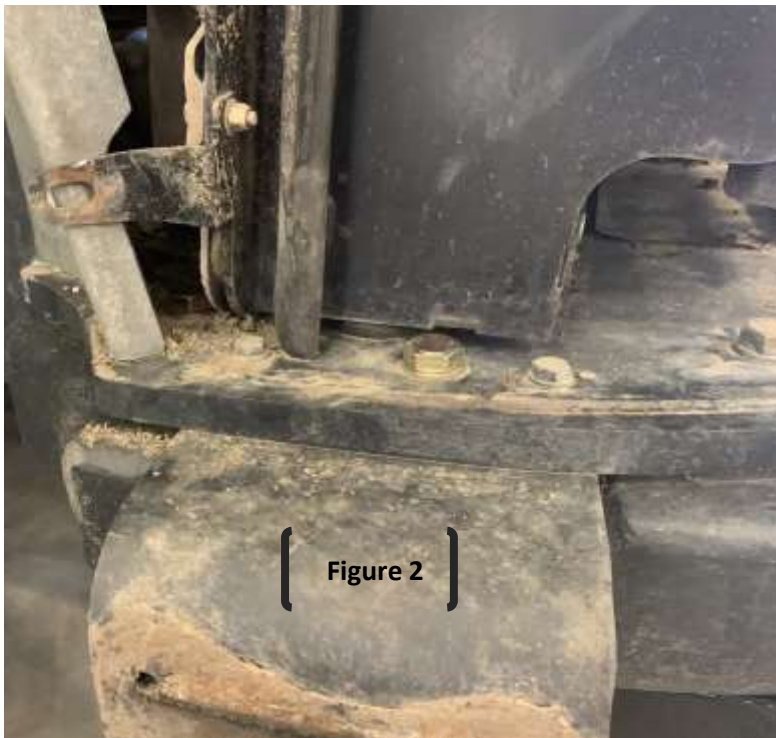
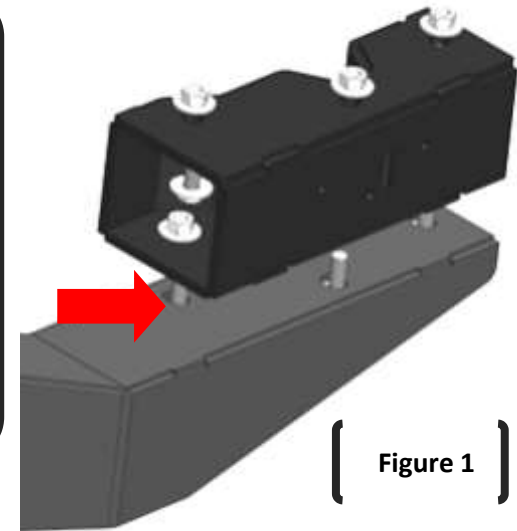

Kit Installation

Refer to Figure 4 & 5

6. Install LANSRCNHT4003 using bolts (LAN25B00), a washer under the bolt head (LANFWS57) and nut on the back side (LAN690830).
7. Tighten all bolts holding the mounts and spacers.
8. Install LANSR005BLK in the upper set of holes on the mount arms using bolts (REDB710), a washer under the bolt head (LANFWS57) and nut on the back side (LAN690830).



Figure 4



Figure 5

Kit Installation

Refer to Figures 6 & 7

9. Attach the stalk roller wings (LANSR038BLK & LANSR039BLK) to the mounts with the pivot pin (LANSR008) and two plastic washers (LANSR009) each.
10. Secure the pins in place with 1/2" x 1.75" hex bolts, 1/2" SAE washers and 1/2" top lock nuts.
11. Grease the wings.



Figure 6



Figure 7

Kit Installation



Figure 8

Refer to Figures 8 & 9

12. Install the cylinders (LANW250100-S) using the pins that come with them.
13. Ensure that both ends have a port that is facing toward the rear of the tractor, the rod end is attached to the wings and the clevis bolt is oriented upward.
14. When the cylinder is completely extended, the wing frame should be parallel to the ground. Adjust it by screwing the clevis in/out of the rod.
15. If the chains on the roller assemblies are not in the middle hole, it is likely they will need to be moved. This can be done now or later when the kit is completed. Simply relieve the chain of tension and move carriage bolt.



Figure 9

Kit Installation

Refer to Figures 10 & 11

16. Hang the roller assemblies from the wings using the U-bolts and remaining flange nuts in the LANSSTFMBH boxes.
17. Slide the roller in or out to cover the track.
18. Make sure that the inner end of the roller is in-line with or outside the hinge pin as shown. (The further out it is the better it will unfold, but needs to cover path of the tires.)



Figure 10

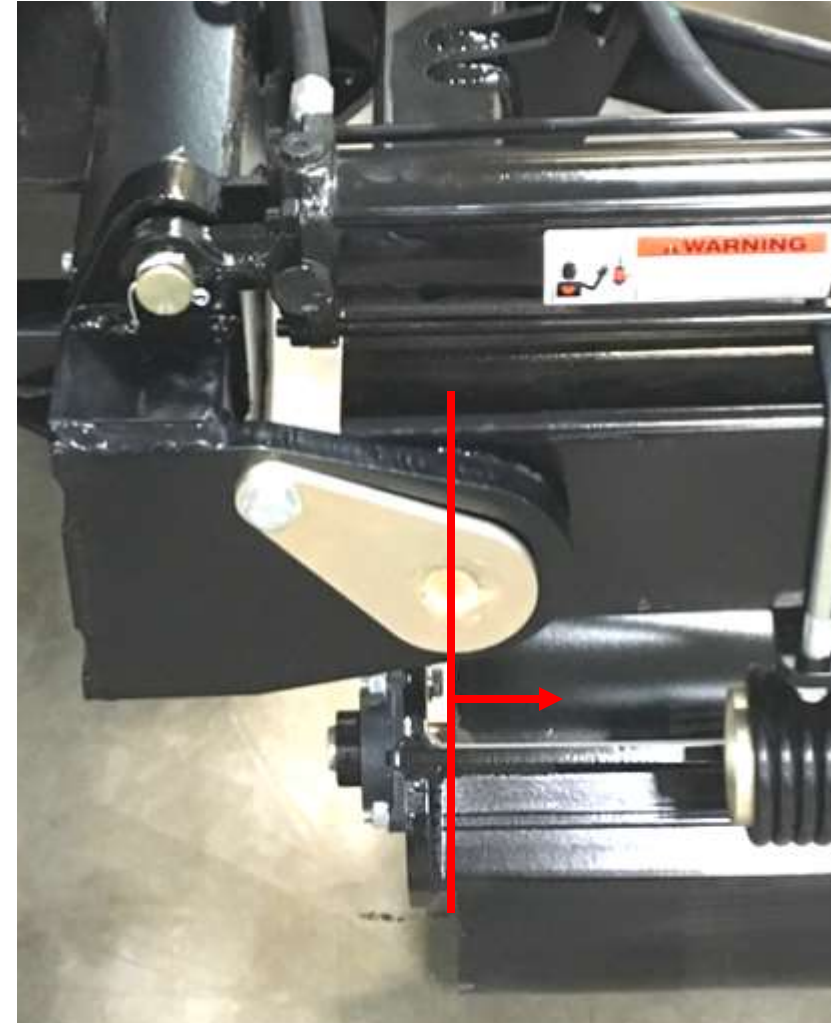

Figure 11

Hydraulic Installation

ITEM NO.	DESCRIPTION	QTY.
1	1/2" FEMALE NPT QUICK COUPLER	2
2	1/2" FEMALE NPT TO 1/2" MALE NPT TEE	2
3	1/2" NPT MALE NIPPLE COUPLING	2
4	9/16" JIC MALE TO FEMALE - 1/32" ORIFICE	2
5	9/16" MALE JIC TEE	2
6	9/16" MALE JIC TO 1/2" MALE NPT	2
7	9/16" MALE JIC TO 9/16" MALE JIC	2
8	9/16" MALE JIC TO 9/16" MALE ORB	2
9	9/16" MALE JIC TO 9/16" MALE ORB 90 DEG	2

LANSRCNH4T - Hydraulic Schematic

* 3/8" Diameter Hoses



Every hose end is crimped with a straight swivel flange fitting.

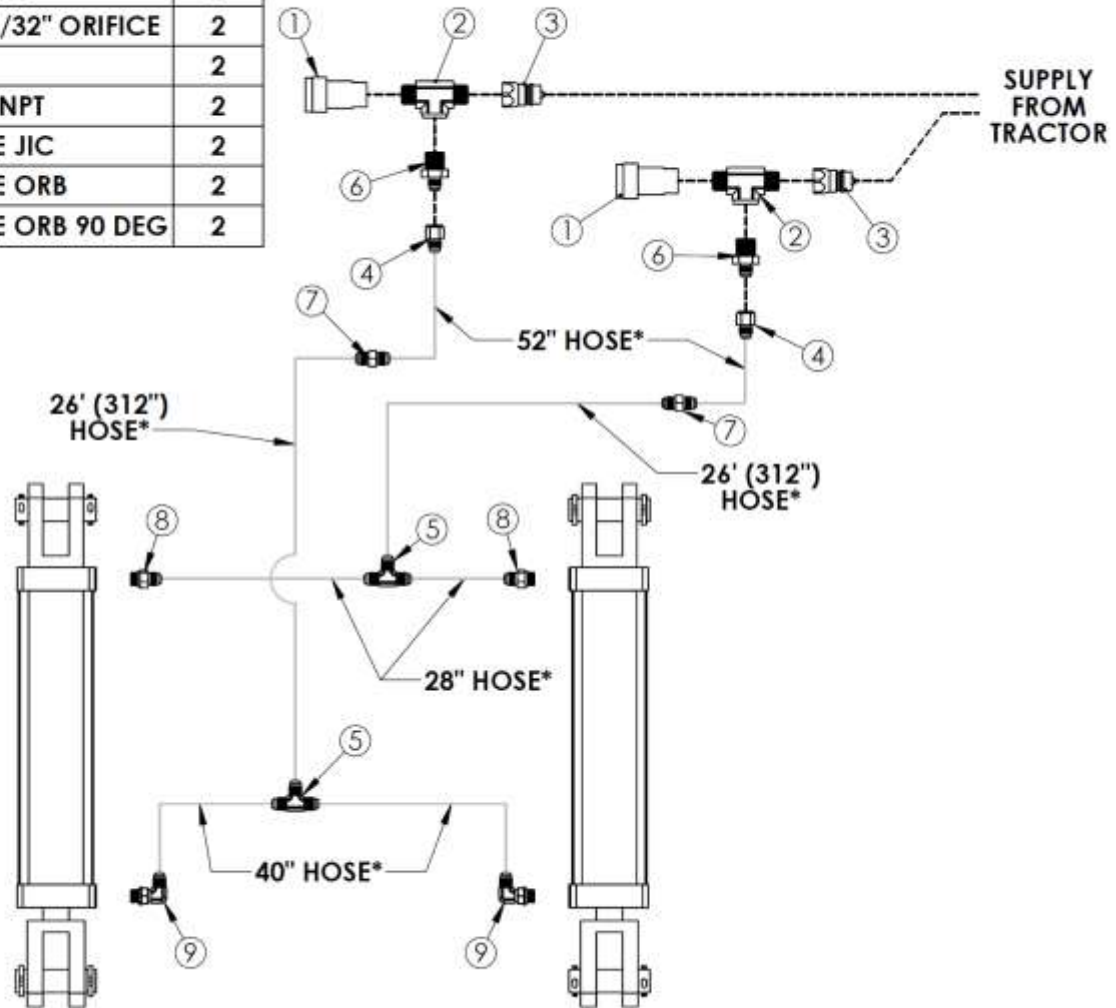

Hydraulic Installation



Refer to Figures 12—18

19. Install the hydraulic fittings, found in the hose kit, into the cylinders as shown.
20. Use the 28" and 40" hoses to plumb the cylinders together.
21. Add the 52" hoses to the 26' hoses with the provided coupler.
22. Two orifices are included and should be used to slow down the hydraulic flow, if needed.
23. Thread the end of the 26' hoses from the rear remotes through the tractor, staying above the differentials, between the chin weight and the frame and out the front. Loosen the right side chin weight bolts slightly if necessary.
24. Tighten the chin weight bolts.
25. Tie up the hoses with the provided zip ties.



Hydraulic Installation



Over Front Differential



Under the Weight



Out Front of Weight



Storage

Refer to Figures 19 & 20

26. 1/2" bent pins (LANSS704) are included in this kit to hold each wing up when storing to prevent the cylinders from settling.
27. To use the pins, push and twist 90 degrees.
28. Use the 1/2" hole in the brackets to store the pins when in use.

Figure 19
Stored

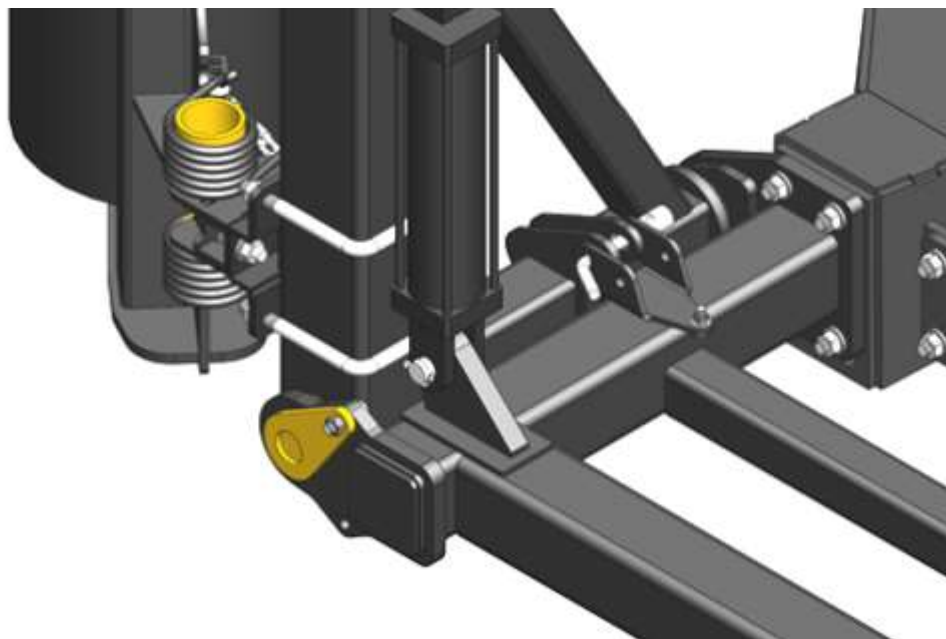
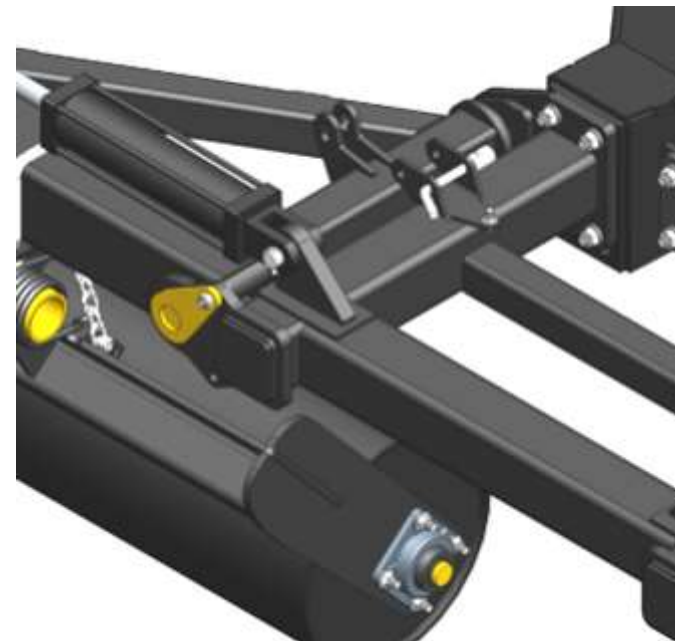

Figure 20
In Use



Headlight Clearance Consideration

Refer to Figures A, B & C

If additional light clearance is required, install cylinder stops (LANSCA-1) as necessary (one or two) on each cylinder to hold the roller arms away from the lights.

Note: The cylinder stops will need to be removed in order to utilize the storage pin position (See Figure C).



Figure A

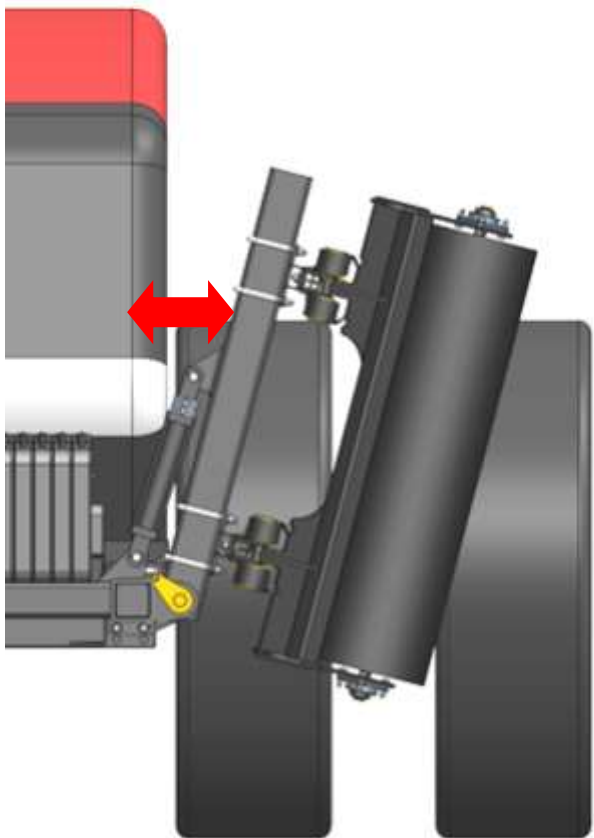

Figure B

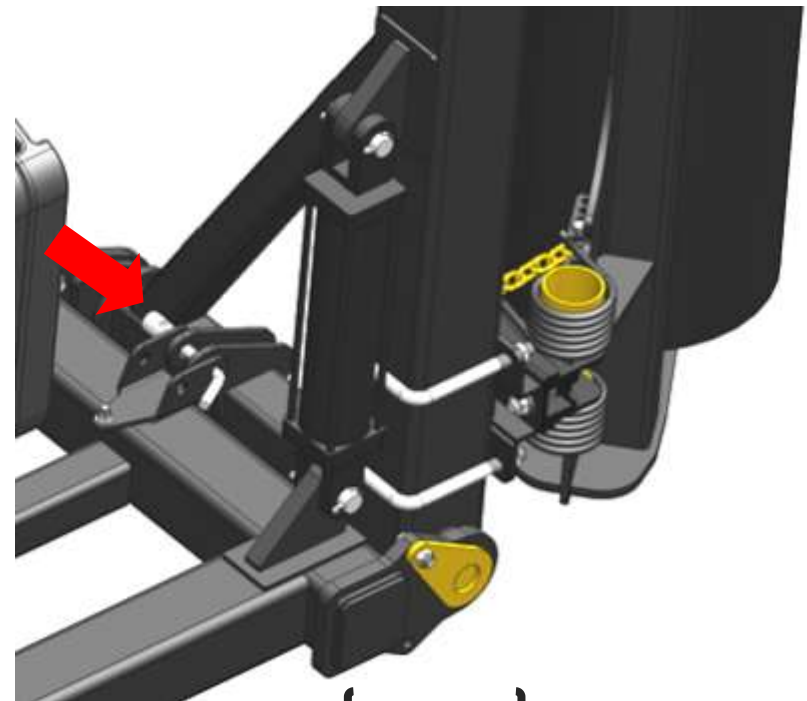

Figure C



For further technical assistance,

Call Lankota Inc. at:

1-866-526-5682