

LANAUGHURK

Installation Instructions

Auger Extensions for High Unload Rate (HUR) John Deere Combines

NOT FOR USE on John Deere X9 Combines

LANKOTA®

270 West Park Avenue

Huron, SD 57350

866-526-5682

Numerical Parts List

Part Numbers	Description	Qty
LANAUGHUR-B	Bearing Hanger	1
LANAUGHUR-C	Access Cover	1
LANAUGHUR-F	Auger Flighting Extension Weldment	1
LANAUGHUR-T1	Saddle Tube	1
LANAUGHUR-T2	Extension Tube	1
LANGS20	Grain Saver Door Weldment	1
LANGS24	Spring Arm	1
LANAUG295	Spring Retainer Band	2
LAN207KRRB12	Bearing	1
LAN105	Bearing Flange	2
LANAUGHUR-S	Auger Spacer	5
LANAUGHUR-JIG	Drill Jig for Auger Flighting Extension	1
LANAUGHURKBH	Bag of Hardware	1
RED305K	3/8"-16 x 1-1/4" Carriage Bolt	13
LAN3718	3/8"-16 Serrated Lock Nut	20
LANH217334	Spring	2
LAN18A	3/8"-16 x 1" Carriage Bolt	5
LAN1618000	3/8"-16 Nylon Lock Nut	2
LANF011G	1/2"-13 x 4-1/2" Full Thread Hex Bolt	1
LANF-HN-0.500C	1/2"-13 Hex Nut	1
REDWL55	1/2" Lock Washer	1
REDB206	5/16"-18 x 1-1/2" Hex Bolt	1
LANF-HN-0.313C	5/16"-18 Hex Nut	1
LANFGCMN	5/16" Bolt Retainer Clip	9
LAN1133	5/16" Flat Washer	6
LANFXG26	5/16"-18 x 3/4" Carriage Bolt Nylon Lock Nut	6
LAN1616	5/16"-18 Nylon Lock Nut	6
LANFS105	1/4" x 1-1/4" Socket Head Screw	1
LANFGXWV	5/16" Drill Bit	1

NOTE: One extra spring is included for replacement if necessary

Pictorial Parts List

						
LANGS20 (1)	LANAUG295 (2)	LANGS24 (1)	LANAUGHUR-T1 (1)	LANAUGHUR-T2 (1)	LAN105 (2)	LANFXG26 (6)
						
LANAUGHUR-B (1)	LANAUGHUR-C (1)	LANAUGHUR-F (1)	LANH217334 (2) *One is a spare	LANFGCMN(9)	LAN207KRRB12 (1)	LANFGXWV (1)
						
LAN3718 (20)	RED305K (13)	LAN1618000 (2)	LAN18A (5)	REDB206 (1)	LANF-HN-0.313C (1)	LAN1133 (6)
						
LANF-HN-0.500C (1)	LANF011G (1)	REDWL55 (1)	LANAUGHUR-S (5)	LANFS105 (1)	LANAUGHUR-JIG (1)	LAN1616 (6)

Preparation

1. Run the auger empty.
2. Fold the auger down
3. Park the combine on a flat surface and set the parking brake .
4. Turn off the combine engine and remove the key.

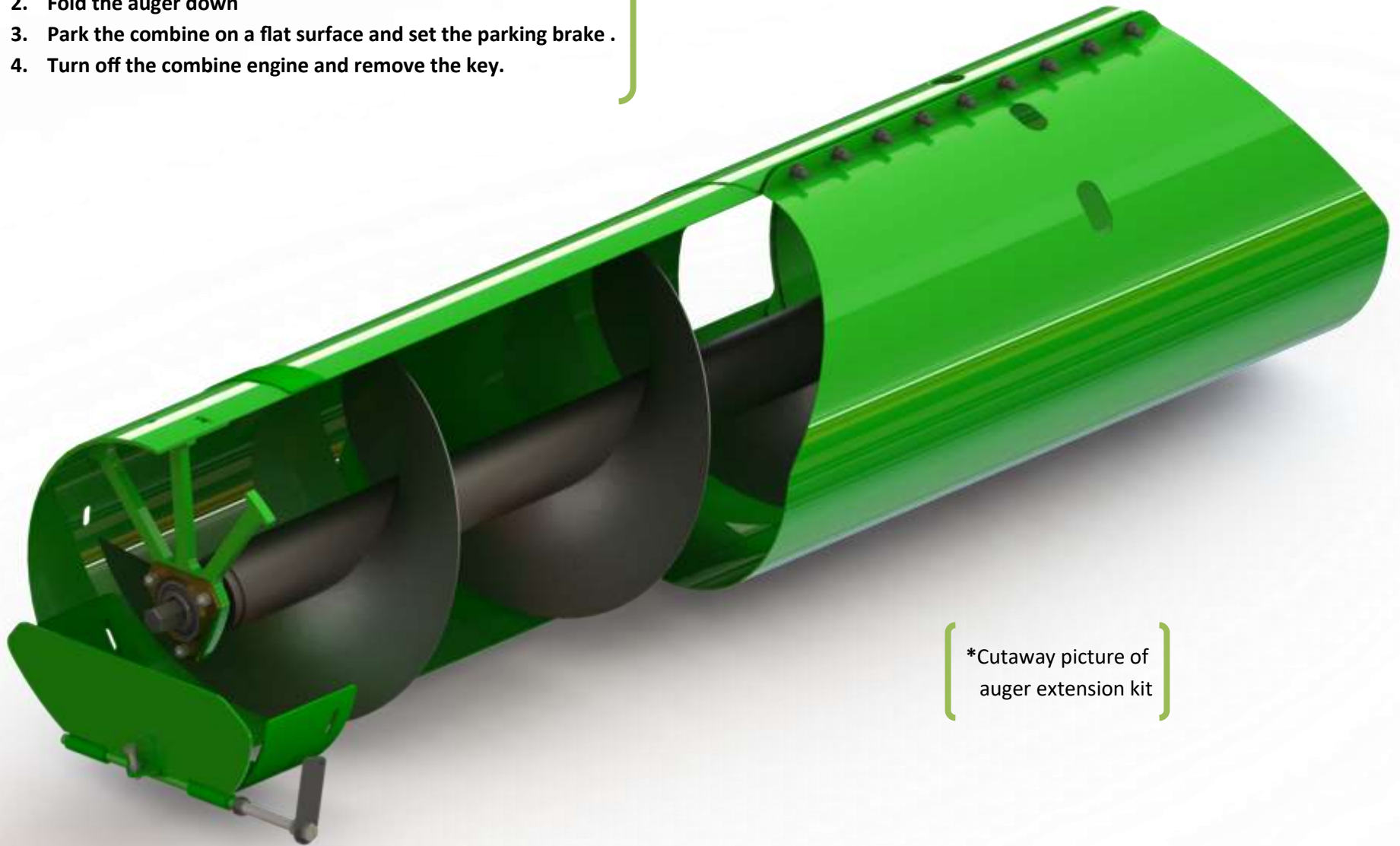

*Cutaway picture of
auger extension kit

Auger Extension Kit

Refer to Figure 1

1. Remove the plastic spout and factory grain saver door from the existing auger tube.
2. Retain all hardware for re-use later in the installation.
3. The factory bearing hanger and its hardware should remain fastened to the existing auger tube.

Refer to Figures 2 & 3

4. Evaluate the Flighting Extension Weldment (LANAUGHUR-F) and determine how it should be timed with the main auger.

Timing auger extension: The new flighting should trail the existing flighting by 90 – 180 degrees.

Note: See Figure 2 for an example of flighting trailing by 120 degrees.

5. Determine and take note of which (2) faces of the main auger hex shaft the retaining bolt will pass through, then remove and set the flighting aside.



Figure 1



Figure 2



Figure 3

Auger Extension Kit



Figure 4

Refer to Figure 4

6. Remove the set screw from the flighting weldment hub and insert in the drill jig.
7. Install the jig onto the main auger hex shaft with the through-hole meeting the previously determined faces that will be drilled.
8. Slide the jig up to the bearing and tighten the set screw.

Refer to Figures 5 & 6

9. Drill out the shaft with the provided 5/16" drill bit.
 - Go very slow to begin.
 - Rotating the auger to drill through the auger tube cutout is required.
 - Drilling from both sides is recommended to minimize wandering.



Figure 5



Figure 6

Auger Extension Kit



Figure 7

Refer to Figures 7 & 8

10. Remove the drill jig and reinstall the set screw in the fighting hub.
11. Attach the fighting extension weldment (LANAUGHUR-F) to the hex shaft of the existing auger, aligning the freshly drilled hole and weldment hub in the process.
12. Install the 1/4" x 1.25" socket head bolt (LANFS105) into the hub and through the drilled channel of the hex shaft.
13. Tighten the bolt and the set screw.

Refer to Figure 9

14. Place the 5/16"-18 x 3/4" carriage bolts in the sides and bottom of the existing auger tube, through the factory slotted holes and retain with the bolt retainer clips.

Figure 9



Figure 8



Auger Extension Kit

Refer to Figure 10 & 11

15. Slide the auger Saddle Tube (LANAUGHUR-T1) over the flighting extension and existing auger tube. Temporarily secure with one LAN305K carriage bolt and serrated lock nut in the top flange.
16. Make sure the 5/16"-18 x 3/4" Carriage bolts (LANFXG26) line up with the slots cut into the Saddle Tube and loosely install the 5/16" Flat Washers (LAN1133) and 5/16"-18 Nylon Lock Nuts (LAN1616). This will secure the Saddle Tube to the factory auger tube.

Note: In Figure 10 there are slots for the existing bearing hanger bolts to fit through on each side.

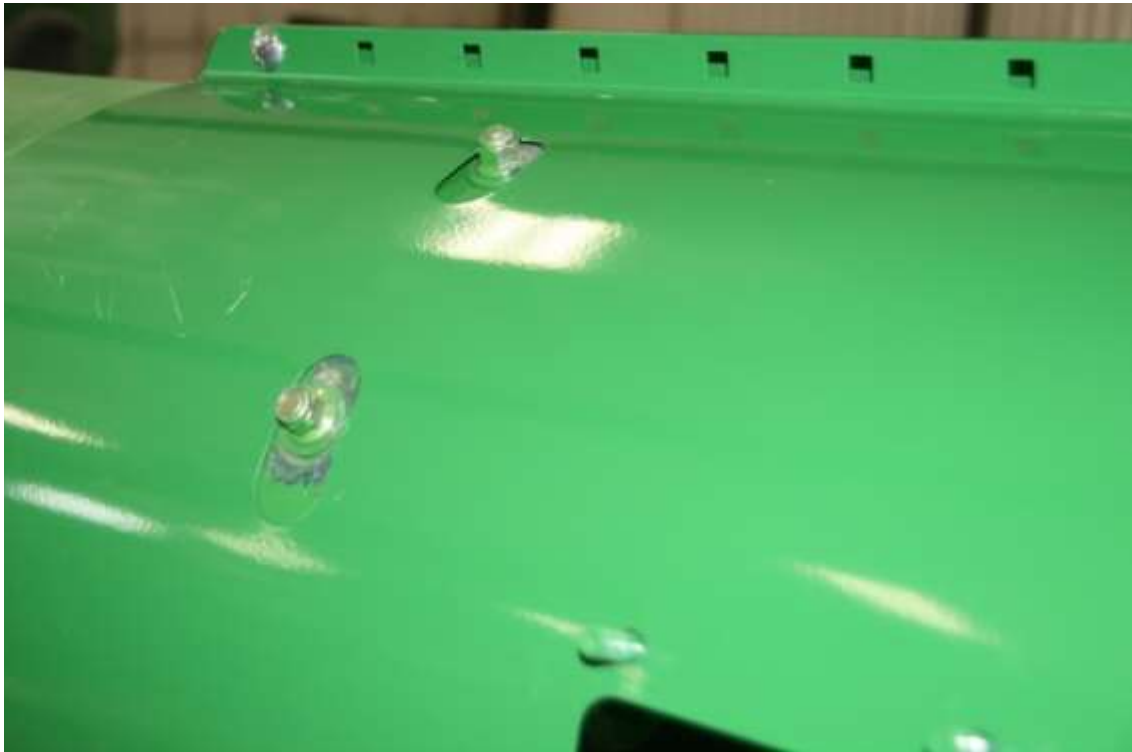

Figure 10



Figure 11

Auger Extension Kit



Figure 12

Figure 13



Refer to Figure 12

17. Slide the auger Extension Tube (LANAUGHUR-T2) into the auger saddle tube and align with the access door. Also make sure the slots on the Saddle Tube(LANAUGHUR-T1) and Extension Tube line up.

Refer to Figure 13

18. Loosely install three 5/16"-18 x 3/4" Carriage Bolts (LANFXG26) with washers (LAN1133) and lock nuts (LAN1616) to fasten the Saddle Tube to the Extension Tube.
19. Install an additional eight LAN305K and serrated lock nuts along the top rib of auger saddle tube. Tighten all hardware.

Auger Extension Kit

Refer to Figures 14 & 15

20. Slide the provided auger spacers (LANAUGHUR-S) over the hex shaft on the provided auger. Make sure enough of them are installed so that they contact the inner race of the bearing once installed. Install the bearing hanger (LANAUGHUR-B) inside the auger extension tube using four of the carriage bolts (RED305K) & lock nuts (LAN3718). Tighten all hardware.

Note the orientation of the slots and square holes in the bearing hanger (Figure 15).

In all instances, SQUARE HOLES MATE WITH SLOTS and vice versa.

21. Support the end of auger flighting extension weldment to the bearing hanger with bearing (LAN207KRRB12) and bearing flanges (LAN105). Install the bearing onto the outer side of the bearing hanger and secure with three LAN18A and LAN3718.

22. Tighten all hardware.

Refer to Figure 16

23. Install the Access Cover (LANAUGHUR-C) and secure with four 3/8" nuts (LAN3718).

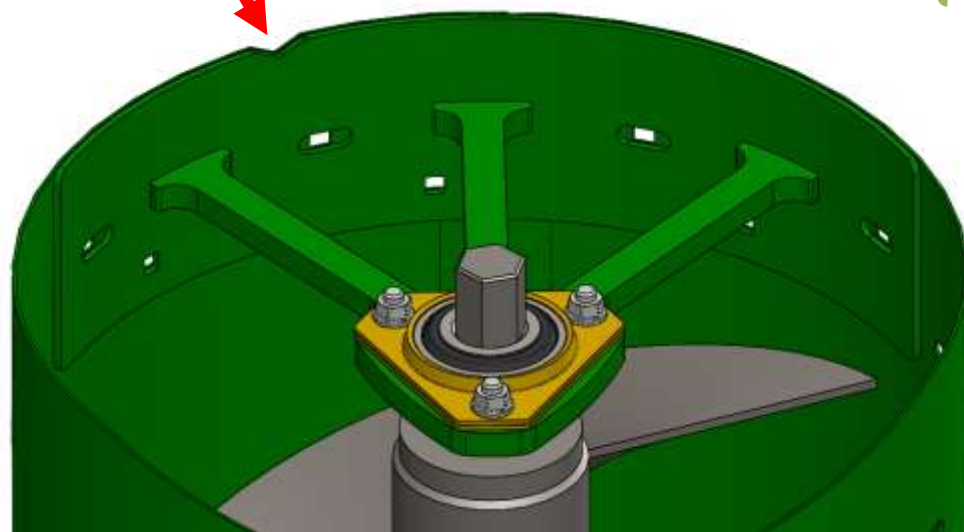

Figure 14



Figure 15

Figure 16



Grain Saver Door Installation

Refer to Figures 17 & 18

1. Install the Grain Saver Weldment (LANAUGHURGS) onto the end of the auger tube as shown below using existing hardware. The two bolts toward the end of the auger (that held the factory door on) should be tightened while four others remain loose for spout installation.
2. Install the stop bolt (LAN3B16A16) and jam nut (LANF-HN-0.313C) into the weld nut on the outside of the grain saver door. This acts as a stop to keep the door from opening up too far.
3. Install the plastic spout and snug up all bolts.

Figure 17

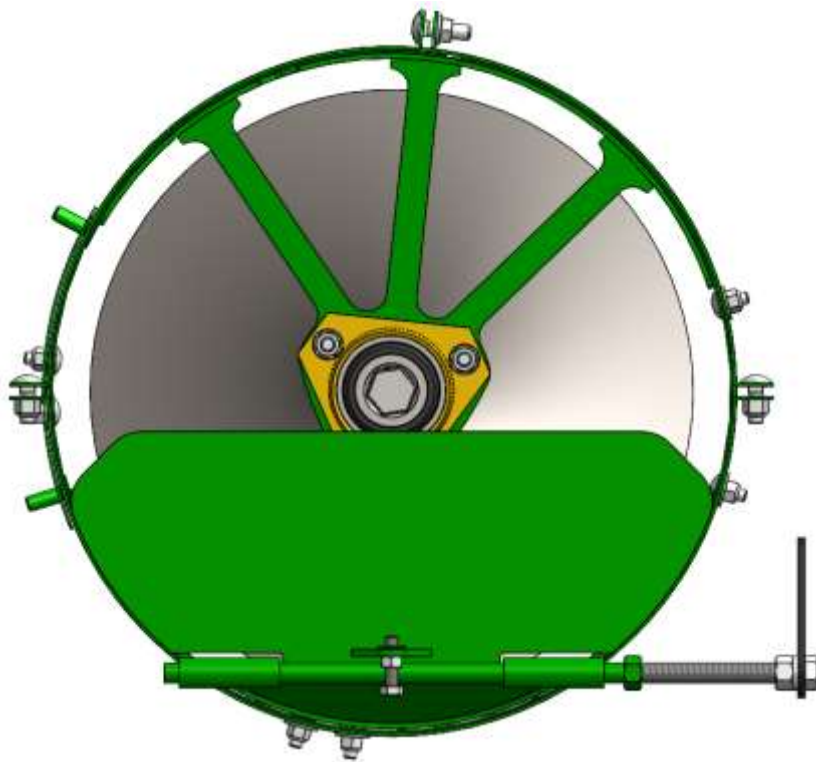
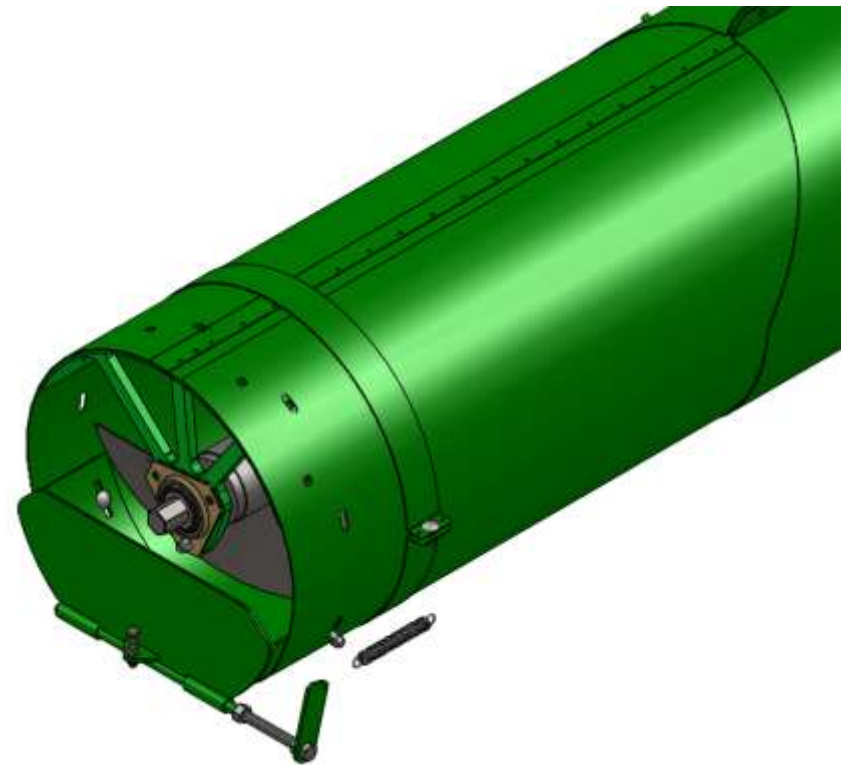

Figure 18



Grain Saver Door Installation

Refer to Figures 19 & 20

4. On the side of the grain saver door with the weld nut, draw a vertical line 5" from the end of the spout. (Figure 19).
5. Along the line, measure up 2-5/8" from the contour line (shown in RED in Figure 20) of the spout and make a mark.
6. Drill a 5/8" hole in the spout where the two lines cross and install the grain saver spring arm.



Figure 19



Figure 20

Grain Saver Door Installation

Refer to Figures 21 & 22

7. The drilled hole should line up with the nut welded to the grain saver door. Using the REDWL55, LANF-HN-0.500C and LANF011G install the grain saver door arm (LANGS24).
8. A good starting point for the band is 3" behind the plastic spout (Figure 21). Assemble the band with two of each: LANAUG295, LAN18A and LAN1618000.
9. Adjust LANGS24 (grain saver spring arm) so the spring length when installed is roughly 9" (the grain saver spring arm should tilt back 10-15 degrees - see Figure 22). Tighten all fasteners for operation. **USE ONLY ONE SPRING ON THE GRAIN SAVER DOOR.**
10. Tighten the nut on the grain saver arm for operation.



Figure 21



Figure 22

For further technical assistance,

Call Lankota Inc. at:

1-866-526-5682

WARRANTY STATEMENT

LANKOTA WARRANTY ONLY COVERS PRODUCTS PRODUCED BY LANKOTA AND DOES NOT COVER PARTS MADE AND/OR SOLD BY OTHER AFTERMARKET MANUFACTURERS, OR THE ORIGINAL MANUFACTURER, OR THAT WERE PART OF THE ORIGINAL EQUIPMENT'S CONSTRUCTION.