

LANBS6FDTA

Installation Instructions

Bean Saver Brush Kit for JD® Flex Draper Heads with Optional Small Diameter Top Auger
(6xxFD & 7xxFD Series)

LANKOTA®

270 West Park Avenue
Huron, SD 57350
866-526-5682

Numerical Parts List

Part Numbers	Description	Qty
LANBS6FD01	Bean Saver Brush	2
LANBS6FD02-03	Brush Holder - (Long) Bottom	2
LANBS6FD02-04	Brush Holder - (Long) Top	2
LANBS6FD03	Bean Saver Brush Mount - Front (2016+ Head)	1
LANBS6FD05	Bean Saver Brush Mount - Front (2015- Head)	1
LANBS6FD06A	Top Auger Mounting Bracket	1
LANBS6FD06B	Top Auger Mounting Bracket	1
LANBS6DF07	Top Auger Brush Mount	1
LANFXG26	5/16-18 x 3/4" Carriage Bolt	4
REDKRJ8	5/16-18 Top Lock Nut	4
LAN1133	5/16" Flat Washer	4
LANBSBH	Bag of Hardware	2
LANFXG26	5/16-18 x 3/4" Carriage Bolt	7
REDKRJ8	5/16-18 Top Lock Nut	7

Preparation

1. **Attach desired header to the combine. Lock the head to the combine.**
2. **Raise the head off the ground and lower the safety stop on the feeder house cylinder.**
3. **Raise the reel all the way up.**
4. **Set the parking brake on the combine.**
5. **Turn off the combine engine and remove the key.**

Pictorial Parts List

 <p>LANBS6FD01 (2)</p>	 <p>LANBS6FD03 (1)</p>	 <p>LANBS6FD05 (1)</p>	 <p>LANBS6FD07 (1)</p>
 <p>LANBS6FD02-03 (2)</p>	 <p>LANBS6FD02-04 (2)</p>	 <p>LANBS6FD06A (1)</p>	 <p>LANBS6FD06B (1)</p>
 <p>LANFXG26 (18)</p>	 <p>REDKRJ8 (18)</p>	 <p>LAN1133 (4)</p>	

Kit Installation - Lower Brush

For a 2016 or newer head:

1. For a 2016 or newer head, proceed to step 2.

For a 2015 or older head:

Refer to Figures 1 & 2

- 1a. Measure and mark a brush (LANBS6FD01) at 52-3/4".
- 1b. Cut the brush at the mark. Crimp the freshly cut end to keep the bristles in.
- 1c. Take a set of brush holders (LANBS6FD02-03 & LANBS6FD02-04), cut each along the outer etch lines. The resulting lengths should be 52-3/4" long.

Figure 2

Figure 1

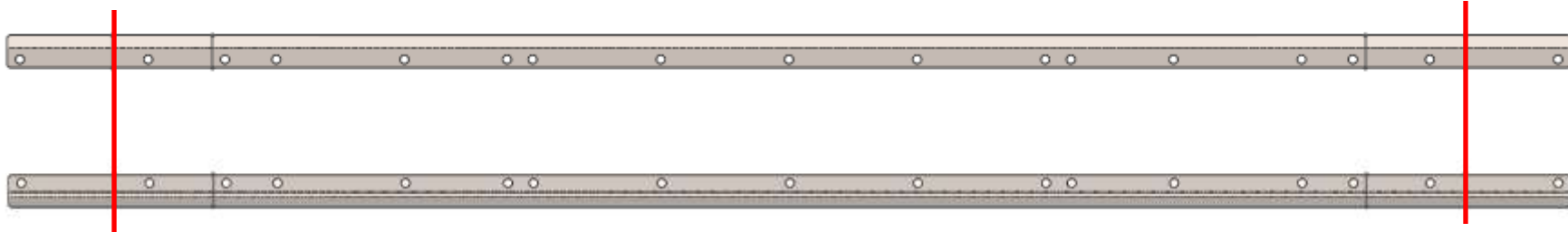

Kit Installation

Refer to Figures 3 & 4

2. Install the brush on the described mounts below; use the provided 5/16" carriage bolts and top lock nuts found in a LANBSBH bag and tighten.

Note: LANBS6FD03 & 05 have slight bends to raise the brush off the canvas. Make sure the bends are pointed up.

2015 Model & Older: LANBS6FD05

2016 Model & Newer: LANBS6FD03

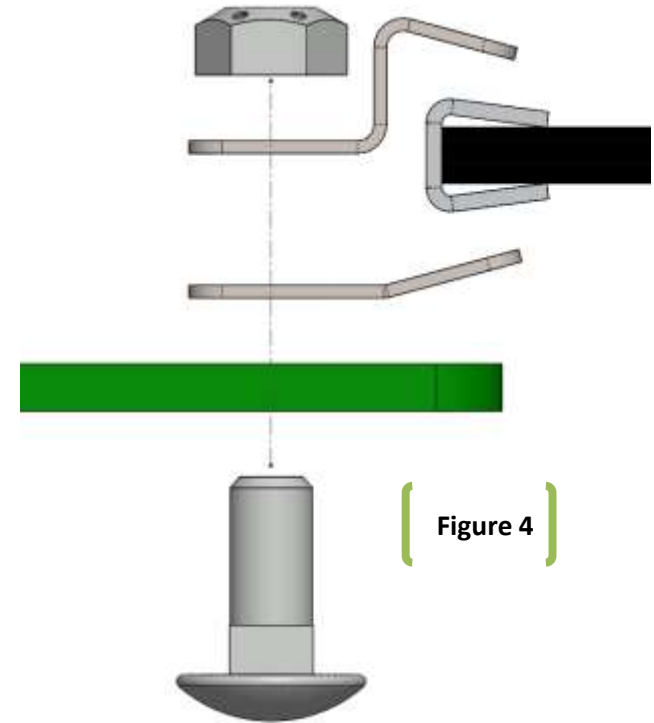

Figure 4

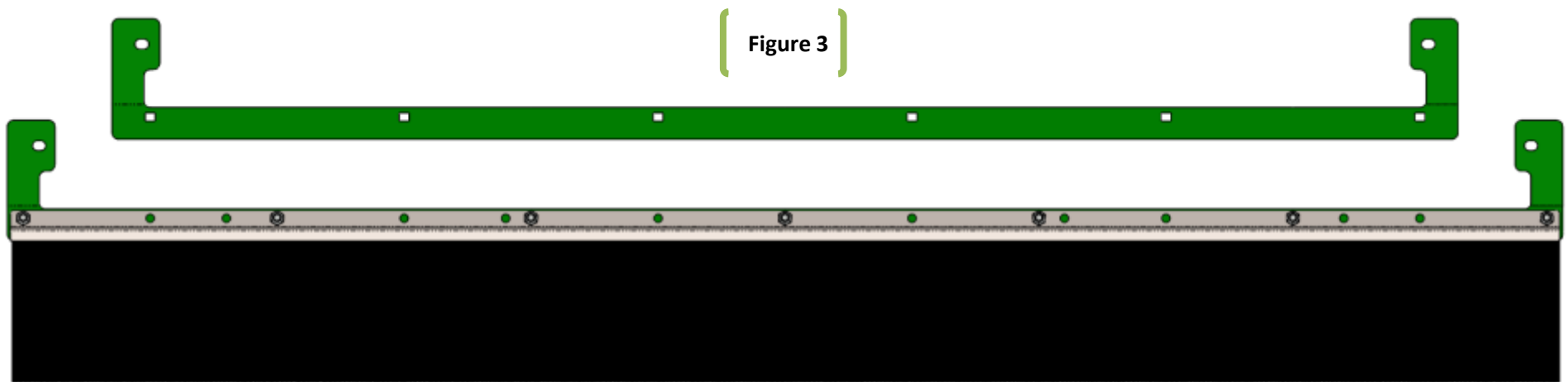

Figure 3

Kit Installation

Refer to Figures 5 & 6

3. Remove the skid plates below the corners of the center canvas (see Figure 7) to access the nut of the socket head bolt (see Figure 8).

Figure 5



Figure 6



Kit Installation

Refer to Figure 7

4. Remove the screw and nut found in the corner of the head on each side as shown.

Refer to Figure 8

5. Attach the lower brush by reusing the removed hardware.
6. Reattach the skid plates.

Note: the holders should be on the TOP side of the bracket.

Figure 8

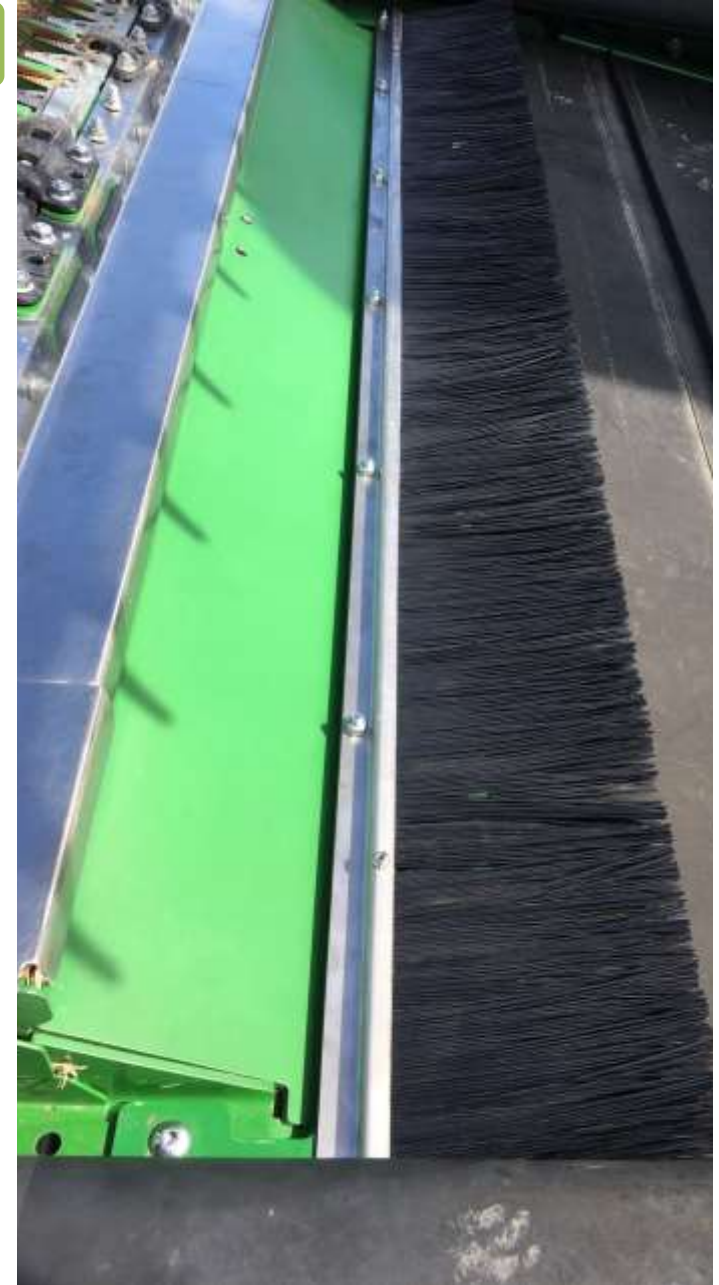

Figure 7



Kit Installation - Upper Brush

Refer to Figure 9

7. Remove the hardware connecting the top auger bearing plates to the brackets above the feederhouse opening.
8. Attach the LANBD6FD06 mounts to the inner side of the auger brackets. Use the previously removed hardware and don't tighten.



Figure 9

Kit Installation

Refer to Figures 10 - 12

For 2016 and Newer Heads

- 9a. Measure and cut the brush (LANBD6FD01) to 53". Recrimp the end to prevent the bristles from falling out.
- 9b. Cut the brush holders (LANBS6FD02-03 & LANBS6FD02-04) along the **OUTER** etch lines (making them 52-3/4").
- 9c. Attach the freshly cut parts to the brush mount (LANBS6FD07). Use the hardware from the bag of hardware (LANBSBH) and tighten.

For 2015 and Older Heads

- 9d. Measure and cut the brush (LANBD6FD01) to 45". Recrimp the end to prevent the bristles from falling out.
- 9e. Cut the brush holders (LANBS6FD02-03 & LANBS6FD02-04) along the **INNER** etch lines (making them 45" as well).
- 9f. Attach the freshly cut parts to the brush mount (LANBS6FD07). Use the hardware from the bag of hardware (LANBSBH) and tighten.

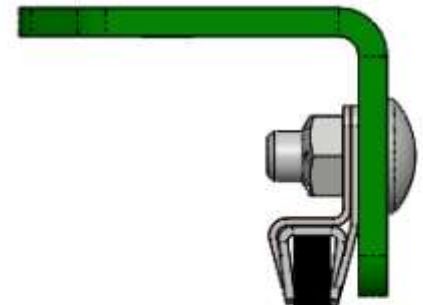

Figure 12

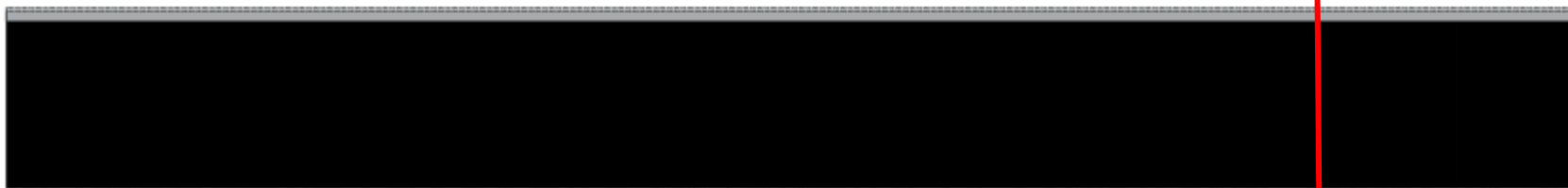

Figure 10

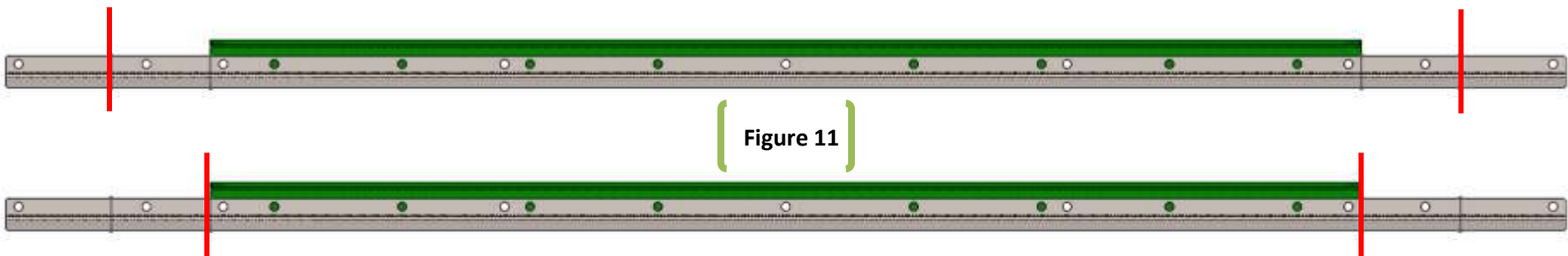

Figure 11

Kit Installation

Refer to Figures 13 - 14

10. Attach the LANBS6FD07 to the mounts with the (4) 5/16" x 3/4" carriage bolts, washers and nyloc nuts. Tighten all loose hardware.

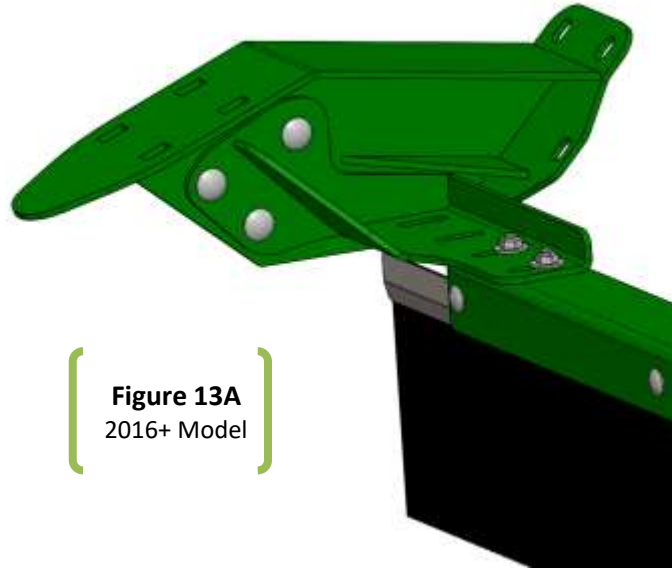

Figure 13A
2016+ Model

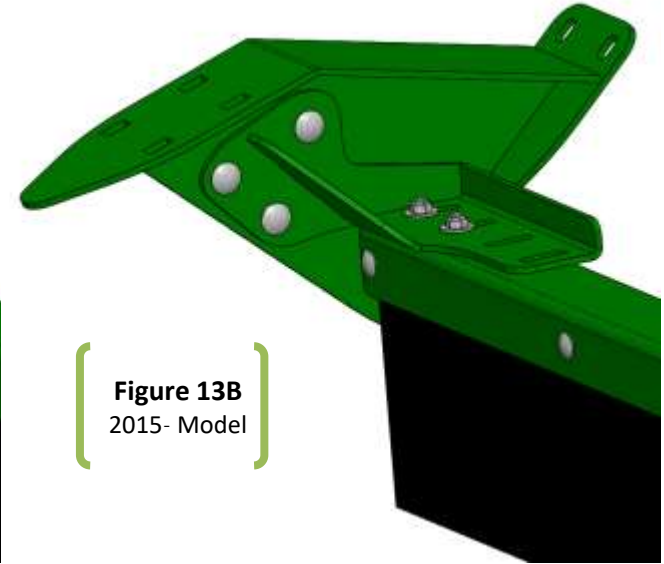

Figure 13B
2015- Model



Figure 14



For further technical assistance,

Call Lankota Inc. at:

1-866-526-5682