

LANSRJD9RX74

Installation Instructions

Lankota Stalk Roller Kit for JD® (2015- Present) 9XXXRX Series Tractors when wider coverage is desired

**** Not for tractors with front weights. Overall tire width coverage is 198" ****

LANKOTA®

**270 West Park Avenue
Huron, SD 57350
866-526-5682**

Numerical Parts List

Part Numbers	Description	Qty
LANSR035	FWA Stalk Roller Assembly	2
LANSR005	FWA Stalk Roller Mount Frame	1
LANSR038	FWA Stalk Roller Wing Frame	1
LANSR039	FWA Stalk Roller Wing Frame	1
LANSR008	FWA Stalk Roller Wing Pin	2
LANSR009	FWA Stalk Roller Plastic Washer	4
LANSR9R100L	Tractor Left Mount	1
LANSR9R100R	Tractor Right Mount	1
LANW250100-S	Hydraulic Cylinder for Stalk Rollers w/ pins	2
LANSRJD8RHK	Hydraulic Hose kit for JD8R Stalk Rollers	1
-----	28" x 3/8" Hydraulic Hose, JIC 6F	2
-----	40" x 3/8" Hydraulic Hose, JIC 6F	2
-----	52" x 3/8" Hydraulic Hose, JIC 6F	2
-----	64" x 3/8" Hydraulic Hose, JIC 6F	2
-----	26 ft (312") x 3/8" Hydraulic Hose, JIC 6F	2
-----	1/32" Orifice Male to Female Adapter	2
-----	9/16" Male JIC to 9/16" Male ORB	4
-----	9/16" Male JIC Tee	2
-----	1/2" Female NPT Quick Coupler	2
-----	1/2" Female NPT to 1/2" Male NPT Tee	2
-----	1/2" NPT Male Coupling	2
-----	9/16" Male JIC to 1/2" Male NPT	2
-----	9/16" Male JIC to 9/16" Male ORB 90 Deg	2

Numerical Parts List

Part Numbers	Description	Qty
LAN8RTC007	Tow Cable Stow Hook	1
LAN-JDTC105	Tow Cable Retaining Latch	1
LANSCA-1	1" Cylinder Stroke Control	4
LANSS704	Stalk Stomper Pin Assembly - Bent Pin	3
LANSRJD9RXBH	Box of Hardware Includes:	1
LAN14M7259	M16 Hex Nut	4
LANF-FW-M16	M 16 Flat Washer	8
LANFE10A	M16 x 80, Cls 10.9 Hex Bolt (Full Thread)	4
LAN18A00	3/8" x 1", Gr 5 Hex Bolt	2
LAN18000	3/8" Flat Washer	2
RED0DTT	3/8" Top Lock Nut	2
LANFC507	1/2" x 1.75", Gr 8 Hex Bolt	2
RED1F30	1/2" Top Lock Nut	2
LANFB810	3/4" x 2.5", Gr 5 Hex Bolt	4
REDKRJG	3/4" Top Lock Nut	4
LANFWS58	3/4" SAE Flat Washer	8
LANFWS57	5/8" SAE Flat Washer	8
REDB712	5/8" x 3.00", Gr 5 Hex Bolt	8
LAN690830	5/8" Serrated Flange Nut	34
REDWL57	5/8" Lock Washer	4
LAN2600UBOLT	5/8" x 4" U-Bolt	1
LAN600UBOLT	5/8" x 2-1/2" U-Bolt	1
LANF-BZBS-0.69-0.50	Bronze Bushing	1
LAN26000	5/8" Flat Washer	1
REDB707	5/8" x 1-3/4" Hex Bolt	1
REDKRJF	5/8" Top Lock Nut	1
LAN079UBOLT	U-Bolt - 5/8" x 6.50"	12

Numerical Parts List

Part Numbers	Description	Qty
LANSRHRTBH	Bag of Hardware Includes:	1
LAN25162	Double 1" Hose Clamp with Cushion	2
REDB204	Hex Head Cap Screw—5/16"-18 x 1.00", gr. 5	2
LANFWS52	5/16" SAE Flat Washer	2
LAN1616	Nyloc Nut - 5/16"-18, gr. 5	2
LAN44302	11" Zip Tie	12

Pictorial Parts List

					
LANW250100-S (2)	LANSR005 (1)	LANSR038 (1)	LANSR039 (1)	LANSR008 (2)	LANSR009 (4)
					
LANSR9R100L (1)	LANSR9R100R (1)	LANSR035 (2)		LAN8RTC007 (1)	LAN-JDTC105 (1)
					
LANSKA-1 (4)	LANSS704 (3)	LAN14M7259 (4)	LAN18000 (2)	LAN18A00 (2)	LANFC507 (2)
					
LANF-FW-M16 (8)	LANFE10A (4)	LANFB810 (4)	RED1F30 (2)	LANFWS57 (8)	REDB712 (8)

Pictorial Parts List (continued)

					
LAN690830 (34)	RED0DTT (2)	LANKRJG (4)	REDWL57 (4)	LANFWS58 (8)	LAN2600UBOLT (1)
					
LAN600UBOLT (1)	LANF-BZBS-0.69-0.50 (1)	LAN26000 (1)	REDB707 (1)	REDKRJF (1)	LAN079UBOLT (12)
					
LAN25162 (2)	REDB204 (2)	LANFWS52 (2)	LAN1616 (2)	LAN44302 (12)	

Disclaimer

This kit from LANKOTA adds 1300 lbs. to the front of a tractor. Never exceed manufacturer's specified load limit on the front of a tractor! This may mean that weights or a weight bracket may need to be removed from the tractor to install this kit.

WARNING: After completing installation, be careful around the wings the first dozen or so times they are folded/unfolded. The process of purging the air from the hoses can cause the wings to jerk up and down dangerously and unexpectedly.

Preparation

1. Park on a flat and level surface.
2. Turn steering wheel so tractor straight.
3. Set the parking brake.

Installation

1. Open the engine hood.
Refer to Figures 1 & 2
2. Remove the front hood seal shrouds (both sides). Save the hardware for reinstall later.
3. Remove the toolbox. Set the bracket aside for later, but the hardware will not be used again.



Figure 1



Figure 2

Installation

Refer to Figures 3 - 5

4. One at a time, remove and replace the (4) flange head bolts on the sides of the radiator frame with an M16 x 80mm bolt (LANFE10A) and a M16 washer (LANF-FW-M16). Tighten bolts.



Figure 3



Figure 4



Figure 5

Installation

Refer to Figures 6 & 7

5. Using a forklift or other suitable lifting device, raise the spacer bracket (LANSR9R270L) into place under the M16 bolts.
6. Secure with (2) of M16 washer, 5/8" lock washer and M16 nut (LANF-FW-M16, REDWL57 and LAN14M7259). Do not tighten, only snug.
7. Insert (2) 3/4" x 2.5" hex bolts (LANFB810) with 3/4" washers (REDWU58) through the bracket and frame.
8. Secure with (2) of 3/4" washer and 3/4" top lock nut (REDWU58 and REDKRJG) Do not tighten; snug one of them.
9. Completely tighten the M16 nuts/bolts, then the 3/4" nuts/bolts.
10. Repeat on other side with LANSR9R270R.



Figure 6



Figure 7

Installation

Refer to Figures 8—10

11. Ideally the top mounting bolts in LANSR005 should be approx. 29" to 31" off the ground. Use either set of mounting holes to achieve this. Using a forklift or suitable lifting device, hold LANSR005 up to the tractor mounting brackets and attach using the 5/8" bolts (REDB712), washers (LANFWS57), and serrated lock nuts (LAN690830).
12. Plastic washers (LANSR009) are provided to eliminate metal to metal contact between the wing frames (LANSR006 & LANSR007) and the mount frame (LANSR005). Make sure these are in place in the following steps.
13. Using the pivot pin (LANSR008) attach the wing frames to the mount frame. Retain the pivot pin with the provided 1/2" bolt (LANFC507) and lock nut (RED1F30). When in the driver's seat, LANSR006 will be on your left, and LANSR007 will be on your right.

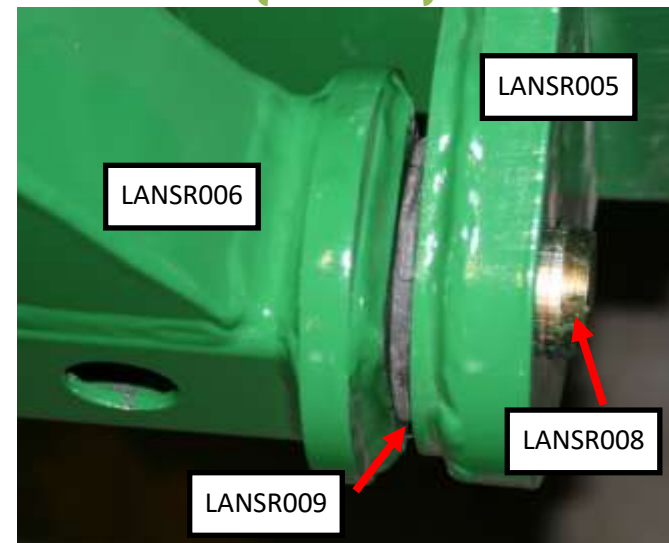

Figure 9

Figure 10



Figure 8



Installation

Refer to Figures 11 & 12

14. Install the hydraulic cylinders (LANW250100-S) with included pins. Make sure the ports are facing toward the tractor and that the rod end is connected to the wing frames (LANSR038 & LANSR039).
15. When the cylinder is completely extended, the wing frame should be parallel to the ground. There is room for minor adjustments by screwing the clevis in/out of the rod.



Figure 11



Figure 12

Installation

Refer to Figure 13

16. Attach three row mounts (LANSSTFM) to each of the stalk roller assemblies (LANSR035) using the 5/8" carriage bolts (RED706K) and serrated flange nuts (LAN690830).
17. Using the provided 5/8" U-bolts (LAN079UBOLT) and serrated flange nuts (LAN690830), attach the row mounts to the stalk roller wing frames (LANSR038 & LANSR039).
18. Slide the roller left or right along the wing to cover the track. Make sure the inner end of the roller is in-line with or outside the hinge pin as shown.

NOTE: The roller drum will be angled toward the back of the tractor.



Figure 13

Hydraulic Schematic

ITEM NO.	DESCRIPTION	QTY.
1	9/16" MALE JIC TEE	2
2	1/2" FEMALE NPT QUICK COUPLER	2
3	1/2" FEMALE NPT TO 1/2" MALE NPT TEE	2
4	1/2" NPT MALE NIPPLE COUPLING	2
5	9/16" MALE JIC TO 9/16" MALE ORB	2
6	9/16" MALE JIC TO 1/2" MALE NPT	2
7	9/16" MALE JIC TO 9/16" MALE ORB 90 DEG	2
8	9/16" JIC MALE TO FEMALE - 1/32" ORIFICE	2

* 3/8" Diameter Hoses



Every hose end is crimped with a straight swivel flange fitting.

LANSRJD8R - Hydraulic Schematic

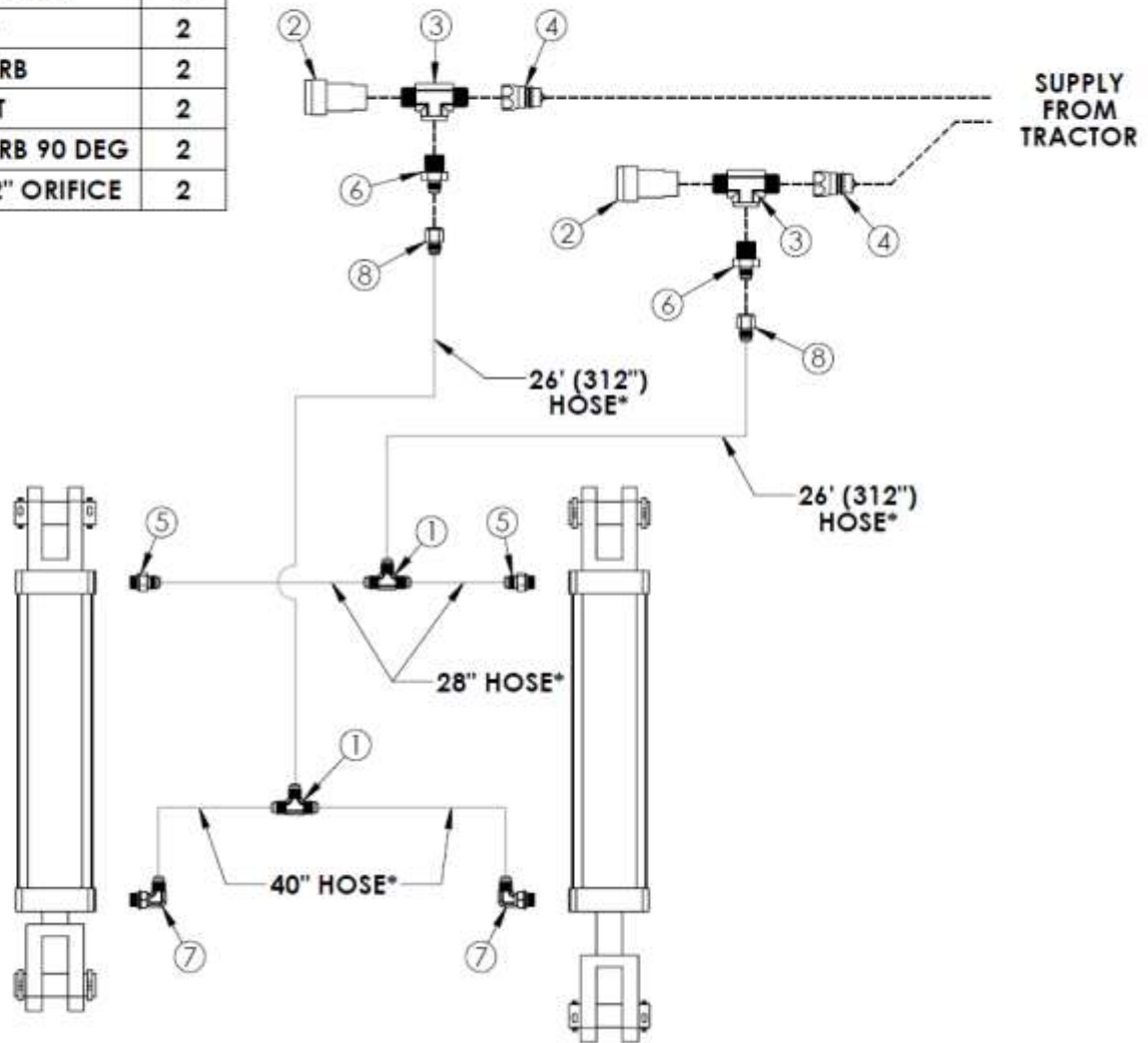

Installation

NOTE: Use the hydraulic schematic on the previous page as a reference for the following hydraulic installation procedures.

Refer to Figure 14 & 15

19. Attach a straight fitting on the base end of the cylinder and a 90 degree fitting on the rod end of the cylinder. A 28" hose will be attached to the straight fitting. A 40" hose will be attached to the 90 degree fitting. Do this on each cylinder.
20. Both sets of hoses will meet up and attach to the tee fittings in the middle. Make sure cylinder base hoses are together and rod end hoses are together. Also make sure that the hoses have enough freedom to move as the wing frames rotate up 90 degrees. Attach the two 312" hoses to the tee fittings and route them under the front end of the tractor.



Figure 14

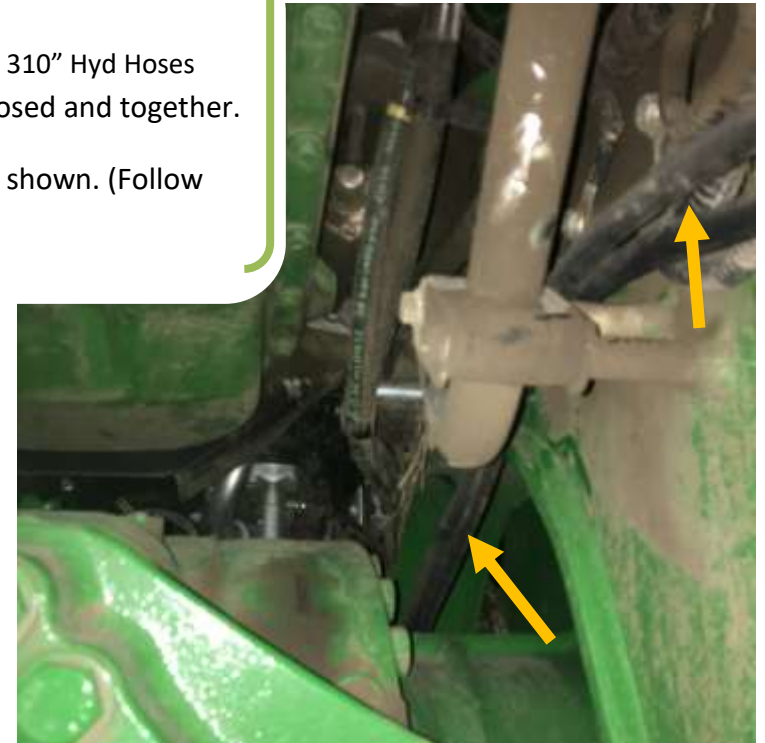

Figure 15

Installation

Refer to Figures 16 - 22

21. Tape the ends of the 310" Hyd Hoses (LANHH4J6-310) closed and together.
22. Route the hoses as shown. (Follow the blue arrows.)



Installation

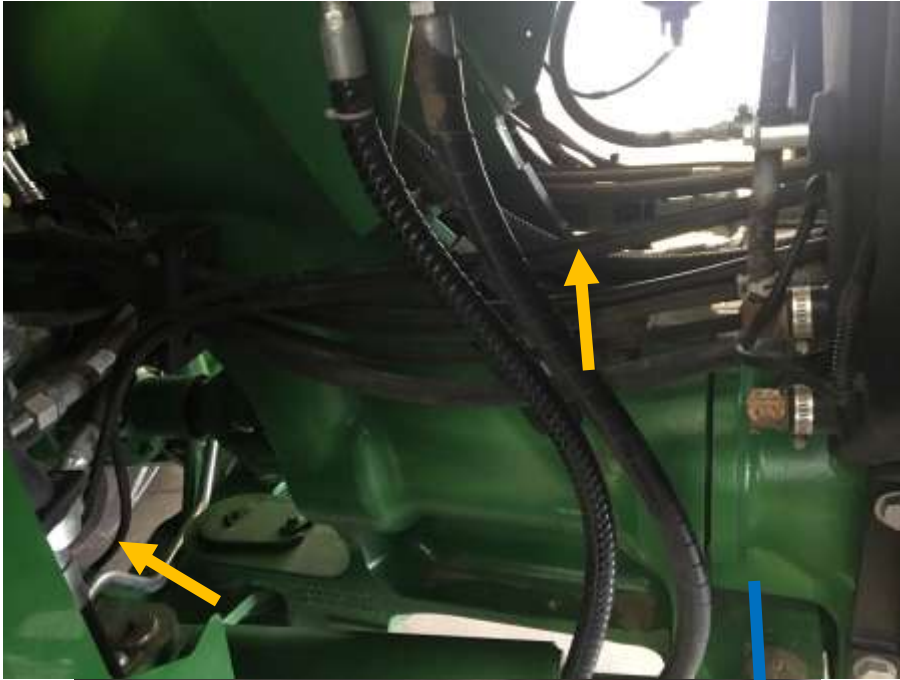

Secure the hoses with zip ties wherever necessary.

Installation

Refer to Figure 23

23. Connect the tee, adapter and pioneer hydraulic fittings together. Attach to the rear end of the 310" hoses and tighten.

Refer to Figure 24

24. Plug into a set of hydraulic ports.
25. Run the hydraulics up and down to purge the air from the lines and cylinders.



Figure 23



Figure 24

Installation

Refer to Figure 25 & 26

26. Two pins (LANSS704) are included to hold the wing frames UP during long term storage. The purpose is to keep the hydraulic cylinders from settling. An extra hole is provided for storage of the pin while the rollers are in use.

Storage Position



Figure 25

Operating Position



Figure 26

Installation

Refer to Figure 27 & 28

27. If equipped with a tow cable kit, use the cable stow hook (LAN8RTC007) and stow latch (LANJDTC105) to hold up the end of the cable. Connect the two with a 5/8" x 1-3/4" bolt (REDB707), bronze bushing (LANF-BZBS-0.69-0.50), 5/8" washer (LAN26000), and 5/8" top lock nut (REDKRJF).
28. Depending on the cable length, use the 5/8" x 4" U-bolt (LAN2600UBOLT) on the front center tube, or the 5/8" x 2-5/8" U-bolt on the rear center tube.

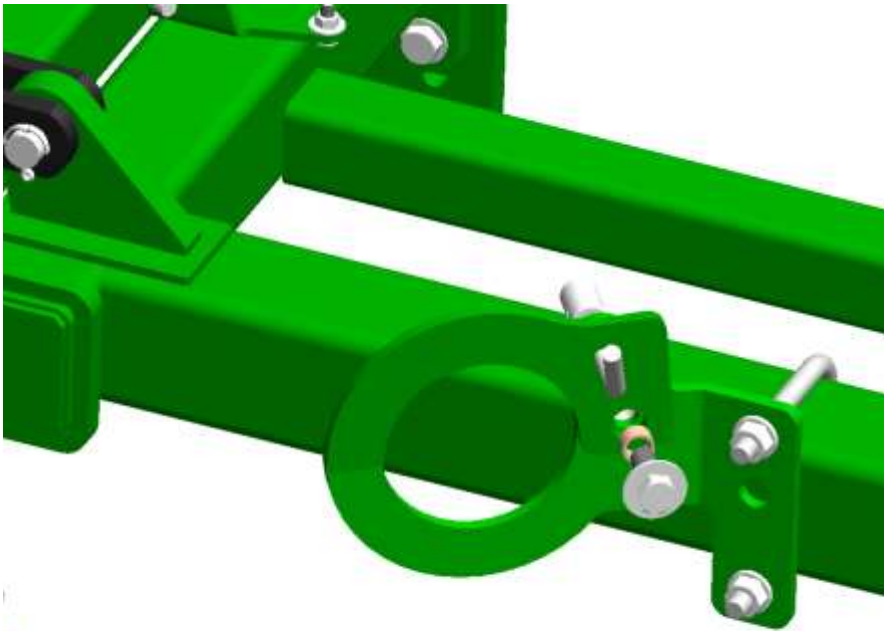

Figure 27



Figure 28

Headlight Clearance Consideration

Refer to Figures A, B & C

If additional light clearance is required, install cylinder stops (LANSCA-1) as necessary (one or two) on each cylinder to hold the roller arms away from the lights.

Note: The cylinder stops will need to be removed in order to utilize the storage pin position (See



Figure A

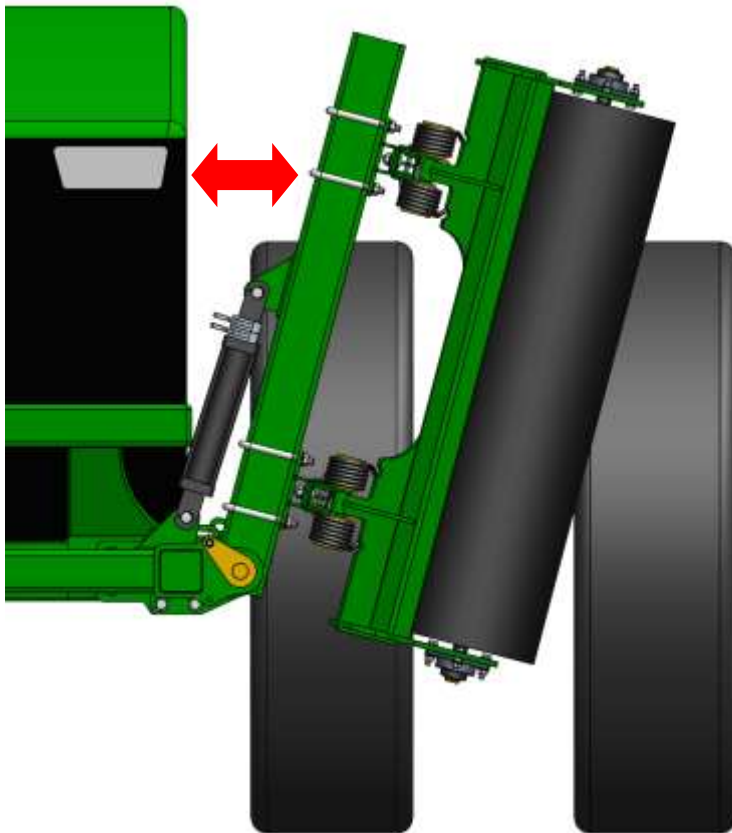

Figure B

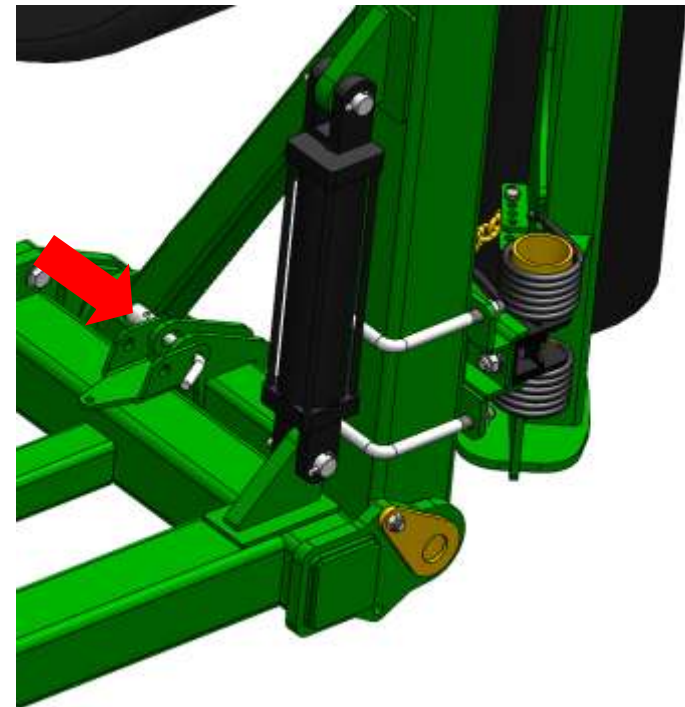

Figure C

Stalk Roller Disclaimer

Stalk Roller Disclaimer

The most effective use of the Lankota Stalk Roller is achieved by adjusting the chain on the roller so that when they are unfolded, the roller drum is just touching the ground and the spring is not compressed. Over compression of the spring can shorten the life of the roller spring and may result in undue damage NOT covered by Lankota's Limited Warranty.



For further technical assistance,
call Lankota Inc. at:
1-866-526-5682